

# SERVICES THAT MAKE THE WORLD SAFER





“

IIA is a trusted technology service partner, and they have earned a reputation for providing cost-effective and innovative inspection solutions. IIA applies best practices and delivers outstanding results.

- Confidential, Defense Contractor



### ACCOUNTABLE

*IIA understands safety is priority in this industry, and we take responsibility for always acting with integrity and in the best interests of our customers, our employees, and the public at large.*



### PROFESSIONAL

*We confidently connect with our customers and are always detail oriented and solution focused. You can count on each of our team members to conduct themselves in a positive and personable way, highlighting IIA's commitment to customer service and respect.*



### ENGAGED

*Everyone within IIA is eager to listen, communicate with, and fully understand our customers' needs and goals. Further, our team finds answers, explores possibilities, and provides successful solutions. Sometimes this means delivering accurate solutions by using traditional technologies or challenging a seeming impossibility and applying a new technology.*



# WHO WE ARE

**In 2015, the founders of Industrial Inspection & Analysis, Inc.® (IIA) began with a vision to build a best-in-class, industrial inspection company with a breadth of high-quality service offerings for a variety of sub-sectors while ensuring a simultaneously important focus on customer service, technical leadership, and continuous improvement.**

IIA offers timely, accurate, and reliable inspections, certifications, and testing solutions in both laboratory and field settings. Our company has grown to serve the whole of North America with a presence across the entire United States and a large growing footprint in Canada and Asia.

As we grow, we remain focused on continuously improving our offerings, educating our already robust bench of expert talent, and expanding our vast service offerings. In doing so, our current and future customers benefit from our expertise, knowledge, connections, and industry leadership.

## **STORY-WORTHY SERVICE**

Whether for a routine inspection or a unique and challenging lab, field, or examination project, IIA is committed to providing professional, fast, and accurate service each and every time. Our customers' success is priority, no matter what, and this is what makes our service story-worthy.



***Current and future customers benefit from IIA's industry expertise and continued expansion.***



# WHO WE SERVE

**IIA provides services to a wide variety of customers across many sectors, including nuclear power, petrochemical, aerospace, defense, municipalities, lifting, and manufacturing.**

We offer Nationwide labs, field inspection services and support the operation, maintenance, compliance, repair, and emergency services to ensure safe, reliable facility operations. We are also the only source you need for Lab and Engineering Services projects, including 3D and Laser Scanning.

- ADDITIVE MANUFACTURING**
- AERIAL DEVICES**
- AEROSPACE AND AVIATION**
- BRIDGES AND INFRASTRUCTURE**
- DEFENSE**
- FIRE DEPARTMENTS**
- FOOD & BEVERAGE**
- GOVERNMENT**

- LIFTING DEVICES**
- MEDICAL**
- MIDSTREAM OIL & GAS**
- PAPER & PULP**
- PETROCHEMICAL AND REFINERY**
- POWER GENERATION**
- PRECISION MANUFACTURING**
- RADIO FREQUENCY DEVICES**

# SERVICES

IIA provides an array of industrial services across several industries. We offer Nationwide field inspection services and support the operation, maintenance, compliance, and repair for your systems to ensure safe, smooth, and reliable facility operations.

We are also the only source you need for all your Lab and Engineering Services projects. We provide full-service crane care, lift inspections, maintenance, modifications, and repairs, and we also provide top-to-bottom inspections for fire trucks, including detailed Fleet Safety Analysis (FSA) reports.



## LAB SERVICES

*As one of the largest dedicated quality service providers in the Nation, IIA is the only lab source you need for Dimensional Inspection, Calibration, Certification, Testing, Failure and Engineering Analysis. We have strategically placed specialized equipment to support our customers throughout North America.*



## LIFTING SERVICES

*We offer comprehensive Crane and Lift services for companies, municipalities, and all organizations that need annual inspections, maintenance, modifications, and repairs for lift and crane equipment, including top-to-bottom inspections of fire trucks. We also track fleet services and provide a detailed Fleet Safety Analysis (FSA) which helps Fleet Managers make critical equipment decisions.*



## INDUSTRIAL INSPECTIONS

*IIA's expert technicians are available 24/7 to support your planned or unplanned inspection needs while keeping safety, compliance, and quality as our top priority. Our multi-disciplined technicians are the go-to experts in providing examinations across the NDE spectrum. IIA offers both traditional and advanced NDE methods that you may not be familiar with. Some of these advanced methods include, but are not limited to, automated ultrasonics, laser profilometry, pulsed eddy current, guided wave and much more. IIA has developed several proprietary NDE techniques and inspection methods to better assist our clients. Understanding the client's needs is paramount to IIA, and we pride ourselves on partnering with our clients to utilize the most efficient and effective methods for examinations and reporting.*



## FIRE EQUIPMENT SERVICES

*We have over 45 years of experience performing inspections and non-destructive testing services. IIA Fire Equipment Services provides fire hose, fire pump and nozzle/appliance testing services to fire stations as well as aerial and lift device inspections and certifications to a variety of companies, public and private utilities, and municipalities across the US and Canada. IIA is one of the only companies in the US that offers onsite, live line testing for the utility industry.*



## ENGINEERING SERVICES

*IIA offers solutions to your engineering challenges by providing design and integrity assessment services for structural, civil, mechanical, and reverse engineering, and also lift planning engineering.*



**VISIT INDUSTRIAL-IA.COM  
FOR MORE INFORMATION.**

# LAB SERVICES

**IIA is one of North America's largest and most trusted full-service providers of industrial and commercial laboratory services.**

IIA is one of North America's largest and most trusted full-service providers of industrial and commercial laboratory services. With a growing international presence and industry-spanning expertise, our Laboratory Services team offers state-of-the-art technology, compliance expertise, and highly skilled technicians to meet the unique needs of your project.

“

Everyone here agrees, IIA is quick in all areas: communication, response, and return of parts. Thank you.

- Tyler Walsh, Protolabs

## SERVICES & TECHNOLOGIES

- Dimensional Inspection
- First Article Inspection
- Mechanical Testing
- Product Testing
- Coating Testing
- Electronics Testing
- Reverse Engineering
- Conventional NDE
- Radiography
- Liquid Penetrants
- Magnetic Particle
- Ultrasonics
- 3D Scanning & Data Capture
- Calibration
- Pyrometry
- EMC, RF & EMF Testing
- Chemical Testing
- Environmental Testing
- Metallurgical Testing
- Oil, Fuel, Coolant & Grease Analysis
- Fluid testing and fuel analysis

## WE CAN ISSUE YOUR APPROVALS FOR USA, CANADA, AND EU SCOPES

- AS9100D Certified
- AS9100 Compliant
- AS9102 Compliant
- AS9110 Compliant
- AS9120 Compliant
- ISO/IEC 17065:2012
- ISO 9001:2015
- ISO 13485: 2016
- ISO 17025:2017
- ITAR Registered
- FAR Part 145 Certification
- ASNT SNT-TC-1A
- A2LA Calibration
- ASNT CP-189
- NAS410
- Federal Firearms License (FFL)
- NADCAP Accredited
- PASNT Certified Level II & III
- A2LA Mechanical Testing
- A2LA Chemical Testing
- CPSC Accreditation
- NADCAP Materials Testing
- NADCAP Non-Destructive Testing
- NADCAP Aerospace Quality System (AC7004)
- Cessna Citation NDI Certification
- Missouri Department of Natural Resources Drinking Water Lab
- Our Facilities Meet a Variety of MIL-SPEC, ANSI, ASTM, and ASME Specifications
- Our Quality Program meets the Nuclear Industry requirements of 10 CFR 50 Appendix B, NQA-1, and ANSI/NCSL Z540.1-1994.



# LIFT SERVICES

As a trusted leader in lift equipment inspections, IIA takes quality and safety to a higher level. With decades of experience, IIA provides on-site inspection and certification to ensure the safety of airline ground support equipment (GSE), overhead and mobile cranes, bucket and fire trucks, and other aerial and lift devices. We inspect all types of lift equipment, each to its corresponding standard. As a full-service provider, our team also includes professional engineers who specialize in lift equipment design, repair, lift planning and accident investigation.

When you partner with IIA, you receive fast, friendly, and professional services with easy-to-read reports and fleet management tracking, which streamlines service and maintenance needs.

## INDUSTRIES WE SERVE

- Fire Departments
- Construction
- Tree Trimming
- Utility
- Mining
- Oil & Gas
- IOUs
- Maritime
- Automotive

“

Industrial Inspection & Analysis exceeded their competitor's inspection rate by 30%.

- Nick Oney, Fleet Manager  
Kendall Vegetation Services

GO TO [INDUSTRIAL-IA.COM](http://INDUSTRIAL-IA.COM) FOR A LIST OF ALL THE INDUSTRIES WE SERVE.



## WE INSPECT THE FOLLOWING TYPES OF LIFT EQUIPMENT AND MORE:

- Fork Trucks & Material Handlers
- Overhead Cranes & Hoist
- Mobile & Conventional Cranes
- Insulated Aerials & Digger Derricks
- Spreader Beams & Man Baskets
- Jib & Gantry Cranes
- Drill Rigs
- Scrap Handlers
- Mining Equipment
- Container Handlers / Reach Stackers
- Airline Ground Support Equipment (GSE)
- Man Lifts & Scissor Lifts
- Vehicle-Mounted Aerials
- Concrete Pumps
- Tower Cranes
- Fire Truck Aerials
- Spreader Beams & Man Baskets
- Mast-Climbing Work Platforms (MCWPs)
- Automotive Lifts
- Floating Cranes (State & Maritime)
- Stevedoring Gear (Maritime)
- Below-the-Hook Lifting Devices
- Rigging
- Fall Protection Systems

## LIFT EQUIPMENT INSPECTION

Our expertise in non-destructive testing (NDT) allows us to accurately detect surface and subsurface defects without damaging the equipment being tested. We offer a variety of complementary NDT, including dielectric, acoustic emission, magnetic particle, ultrasonic, visual and operational inspections. Our services include:

- Visual/Operational Inspections
- Load, Drift, Timing Tests
- Proof Testing
- Dielectric Testing
- Hardness Test of Non-Ferrous Metal Components
- Magnetic Particle and/or Dye Penetrant
- Test of Critical Welds and Casting
- Hydraulic Oil Analysis
- Ultrasonic Inspection of Accessible Pins
- Turntable Bolt Torque Check
- Waterway Systems Check
- Horizontal Bend Test of Ground Ladders
- Ground Ladder Hardware and Hook Tests
- Extension Ladder Hardware Test
- Heat Sensor Check and Replacement
- Liquid Penetrant Inspection of Rung Welds
- Rack Testing
- Hot Stick Cleaning, Waxing, Testing
- Laboratory Equipment Examination
- Wet Testing at 75,000 V/Foot
- Dry Testing at 50,000 V/Foot
- DOT & BIT Inspection
- Opacity Testing (Diesel Smoke Test)
- Post-Accident Inspections
- Insurance Estimates for Repairs
- Computer-Generated Onsite Reports
- Repairs

## CERTIFICATIONS & GUIDELINES

- ANSI A92.2, ASTM 914, and Crane Certification Association of America Committee Members on Staff
- Insurance Coverage Beyond General Liability – Errors and Omissions Insurance
- Internal Quality Control and Quality Assurance Audit Programs
- ISO/IEC 17020 Accredited
- Federal OSHA Certified
- Cal-OSHA Certified
- Fed-OSHA Maritime
- Washington State Construction Crane Certified
- Institute of Electrical and Electronics Engineers (IEEE) Standard 978
- OSHA 29 CFR Part 1910
- ASME

# CRANE SERVICES

**IIA is equally focused on quality and safety, which makes us the full-service industry leader for your crane inspections.** With decades of experience, you can trust our experts for all your crane inspection needs.

We are always up-to-date on the latest standards, regulations, and technology affecting the lift industry through participation on standards committees and user associations. We track your fleet's inspection needs and inform you when your equipment is due for inspections.





## **WE INSPECT THE FOLLOWING TYPES OF CRANE EQUIPMENT AND MORE:**

- Overhead Cranes & Hoist
- Mobile Cranes
- Conventional Cranes
- Tower Cranes
- Floating Cranes
- Stevedoring Gear

## **SERVICES & TECHNOLOGIES**

- Crane Inspections (Overhead, Mobile & Conventional)
- Lifting Device Inspections
- Strap and Sling Inspections
- Predictive Maintenance
- Personal Safety Equipment Inspections (Harness, Lanyards, etc.)

## **CERTIFICATIONS & GUIDELINES**

- New Mexico GS-29 License Number: 90472 California Number : 815024
- Internal Quality Control and Quality Assurance Audit Programs
- Level III NDT on Staff On-Site Safety Coordinator
- ANSI A92.2, ASTM 914 and Crane Certification Association of America Committee Members on Staff
- ISO/IEC 17020 Accredited
- Federal OSHA Certified
- Cal-OSHA Certified
- Fed-OSHA Maritime Accredited
- Washington State Construction Crane Certified



# FIRE EQUIPMENT TESTING SERVICES

IIA's Fire Department Testing Division understands that under the best of circumstances, being the leader of a station is a demanding task. Between fighting fires, responding to medical emergencies, assigning duties, and conducting training, you must also track and schedule annual truck inspections. Our experts understand those pressures and know exactly what you need. IIA guarantees a streamlined and worry-free inspection experience for you and your station every time.

**With our system, our experts can inspect 20,000 feet of hose per day and reload at a 90% faster rate.**

“

Thank You for coming out and doing our inspections on such short notice. It's greatly appreciated. IIA's technician was top notch. He was very knowledgeable and friendly, and we are going to have him back to perform our next inspections. Thank you!

- City of Redfield Fire Department

VISIT [INDUSTRIAL-IA.COM/IIA-FIRE-DEPARTMENT/](https://www.industrial-ia.com/IIA-FIRE-DEPARTMENT/)



## SERVICES & TECHNOLOGIES

### Fire Hose Testing

- Hard Suction Hose per NFPA 1962 section 7.5 using a dry vacuum versus the typical hydrostatic test

### Fire Pump Testing

- Visual Inspection (undercarriage)
- Gathering of critical apparatus, engine, and pump information
- Capacity test, 100% at 150 PSI for 20 minutes
- Overload test, 100% at 165 psi for 5 minutes
- 70% test, at 200 PSI for 10 minutes
- 50% test, at 200 PSI, for 10 minutes
- Gauge Accuracy

### Aerial and Ground Ladder Testing

- Visual Inspection
- Horizontal Bend Test
- Roof Hook Test
- Hardware Test

## CERTIFICATIONS & GUIDELINES

- Adheres to all EVT and strict NFPA standards
- Ground ladders are in accordance with the current NFPA 1932 guidelines
- Complete inspection and non-destructive testing program to meet the current NFPA 1911 as well as 1932-2010 guidelines
- ISO/IEC 17020 Accredited

# INDUSTRIAL INSPECTION SERVICES

**We are the go-to industry expert for Non-Destructive Examination (NDE) services for various industries and locations that include day-to-day and scheduled maintenance/ regulated inspections, new construction projects and last-minute emergent issues. We support our clients utilizing the latest NDE technologies such as Phased Array, Guided Wave, Automated UT, Laser profilometry Etc. Complimenting these technologies, IIA offers a long list of traditional NDE methods such as X-Ray, Magnetic Testing, Dye Penetrant Testing, UT thickness, Conventional UT, etc.**

We have decades of diverse experience in providing weld quality inspection services for power generation outages, rail car qualifications, In-Line-Inspection validation for mid-stream and much more. Our Remote Visual Inspection Services (RVI) supporting foreign object retrievals, as well as remote access verification of quality and cleanliness as well as supplying additional visual options when other NDE methods are not feasible.

“

IIA's NDT technicians are the best in the industry. Nobody in this industry compares to the top-notch team I've worked with from IIA.

- Chris, NDE Manager,  
NORTH AMERICA'S LARGEST  
TANK CAR MANUFACTURER



## TRADITIONAL NDE

- Radiography (RT/CR/X-Ray)
- Magnetic Particle (MT)
- Penetrant Testing (PT)
- Ultrasonic Thickness Testing (UTT)
- Visual Testing (VT)
- Post Weld Heat Treatment
- Corrosion Mapping
- Ferrite Testing
- Hardness Testing
- Positive Material Identification (PMI)
- Program and Procedure Development

## ADVANCED NDE

- Automated Corrosion Mapping (Internal)
- Automated Corrosion Mapping Laser Profilometry (External)
- Phased Array (PAUT) Manual & Automated
- Full Matrix Capture (FMC)
- Time of Flight Diffraction (TOFD)
- Shear Wave
- Guided Wave Testing (GWT)
- In-Line Inspection (ILI Validation)
- Pulsed Eddy Current
- Weld Quality Inspection

## SPECIALTY NDE

- Proprietary Technologies
- Phased Array Sectorial Scanning PASS® Valve Examinations
- Precision Ultrasonic Testing
- Absolute Recordable Manual Ultrasonic Testing (ARMUT®)

## RVI

- Internal Visual Inspections of anything from ¼" and above

## CERTIFICATIONS & GUIDELINES

- All Certifications Based on ASNT Guidelines
- Multiple State Licenses for Radioactive Materials
- In-Line Inspection Validation (ILI)
- Compliance to Pressure Equipment Directive 97/23/EC (European Certification)
- Compliance to Pressure Equipment Regulations 1999, ASNT Level III
- IRRSP Certified



# PLANT SERVICES

**Industrial Inspection & Analysis (IIA) is the go-to professional providing safe, quality inspections for outage and maintenance needs across North America.** IIA's breadth of technicians are certified to industry standards, understand your plant operations, and have the ability to respond to multiple concurrent outages. Our team provides outage planning; as well as visual, magnetic particle, penetrant, and ultrasonic inspections; and much more. IIA's team ensures the continued reliability and availability of your plant.

We have been serving the pulp and paper and power industries decade after decade and are the trusted leader in these sectors. Our team consists of highly qualified professionals, including Certified Welding Inspectors, who provide expert and story-worthy service each and every project.

“

IIA's responsiveness in completing three last-minute and urgent projects is appreciated, and IIA's team did a fantastic job in communicating, sharing in that sense of urgency, and providing us with exactly what we wanted.”

- Gregg Maddox, Great Plains Industries





## SERVICES

- Outage Planning
- Boiler Visual Inspection
- Tank and Piping Inspections
- Burner Set Up
- Quality Control/Quality Assurance
- Hydrogen Damage Inspection
- API 653 Tank Inspections
- API 570 Piping Inspections
- API 510 Pressurized Vessels
- IRIS & Near Drum Testing
- Finite Element Analysis (FEA)
- Fitness-for-Service (FFS) Evaluations
- Tmin (Minimum Allowable Thickness) Calculations for Service Water Piping Systems

## INSPECTION METHODS

- Visual Inspections
- Eddy Current Testing
- Magnetic Particle Testing
- Penetrant Testing
- Radiographic Testing (RT)
- Ultrasonic Mapping and Inspections
- Ultrasonic Shear Wave Weld Examinations

## CERTIFICATIONS & GUIDELINES

- All Certifications Based on Guidelines in SNT-TC-1A and CP189
- In-Line Inspection Validation
- American Welding Society Pressure Equipment Directive 97/23/EC (European Certification)
- Pressure Equipment Regulations 1999
- ASNT Level III
- IRRSP
- CWB Certified CSA W178.10
- ISO 9001:2015 Registered QMC
- ISO/IEC 17025:2005
- ISO/IEC 17065:2012

# NUCLEAR SERVICES

**IIA offers full-service exams, support, solutions, and equipment, ensuring your plant is safe, clean, and compliant.** IIA also provides strategic partnership support for Section XI and non-Section XI examinations.

IIA provides maintenance services and a variety of automated and manual Non-Destructive examinations (NDE). We use a combination of conventional, cutting-edge technologies and proprietary technologies, including Phased Array Sectoral Scanning (PASS™), AIRIS, ARMUT, and coordinating data tracking software.

We conduct thorough and reliable facility inspections and deliver critical information in a timely manner for every part of your facility and all critical components: piping, core shroud, dissimilar metal welds, storage tanks, steam generator, dryer and heat exchangers, turbines, Threads in Flange (TiF), Boiling Water Reactor (BWR), Pressurized Water Reactor (PWR), specialty reactors, and more.



**FOR MORE INFORMATION, VISIT  
[INDUSTRIAL-IA.COM/IIA-INDUSTRIAL-INSPECTIONS/NUCLEAR-SERVICES/](https://www.industrial-ia.com/IIA-INDUSTRIAL-INSPECTIONS/NUCLEAR-SERVICES/)**



## SERVICES & TECHNOLOGIES

- Computed Radiography
- Conventional Radiography
- Dye Penetrant Testing
- Magnetic Particle Testing
- Phased Array UT
- Ultrasonic Thickness Testing
- Finite Element Analysis (FEA)
- Fitness-for-Service (FFS) Evaluations
- Tmin (Minimum Allowable Thickness) Calculations for Service Water Piping Systems
- Advanced Inspection of Reactor Vessel and Internals System (AIRIS™)
- Absolute Recordable Manual Ultrasonic Testing (ARMUT®)
- Phased Array Sectorial Scanning (PASS®) Visualization Software

## CERTIFICATIONS & GUIDELINES

- All Certifications Based on Guidelines in SNT-TC-1A and CP189
- Texas Department of State Health Services – Radioactive Materials Licensing (MC 2835)
- New Mexico Environment Department Radioactive Material License
- In-Line Inspection Validation
- 10CFR50, Appendix B
- OCFR, Part 21
- ANSI Standard N45.2
- American Welding Society
- Pressure Equipment Directive 97/23/EC (European Certification)
- Pressure Equipment Regulations 1999
- ASNT Level III
- IRRSP
- ASME NQA-1
- NUPIC and NIAC Approved Vendor

# ENGINEERING SERVICES

**Dedicated to solving quality concerns and design challenges, we create comprehensive and cost-effective engineering solutions.**

We offer Structural Engineering services for industrial, commercial, institutional, and construction projects. We have several specialties, including steel and concrete, open web steel joist reinforcements, and concrete slab design. Our Mechanical Engineering experts assist in the following areas: Lift Equipment, Lift Planning, Machine Design and Drafting, Design Validation, Finite Element Analysis (FEA), Fitness-for-Service (FFS) Evaluations, T<sub>min</sub> (minimum allowable thickness) Calculations for Service Water piping systems, and Fall Protection Services. We also provide 3D Scanning for reverse engineering, geometry recreation, and 3D modeling to serve an array of applications and industries.

As a full-service provider, IIA's licensed professional engineers work closely with our non-destructive examination (NDE) experts to deliver turnkey solutions to clients in every industry.

“

IIA is our company's preferred vendor for 3D inspection and reverse engineering projects. IIA is an **excellent choice for quick inspection projects** or an alternative to our internal operations.

- *Nate Taylor, Allegion*

**FOR MORE DETAILED INFORMATION ABOUT OUR EXTENSIVE ENGINEERING SERVICES, VISIT [INDUSTRIAL-IA.COM/IIA-CANADA-ENGINEERING-SERVICES/](http://INDUSTRIAL-IA.COM/IIA-CANADA-ENGINEERING-SERVICES/)**

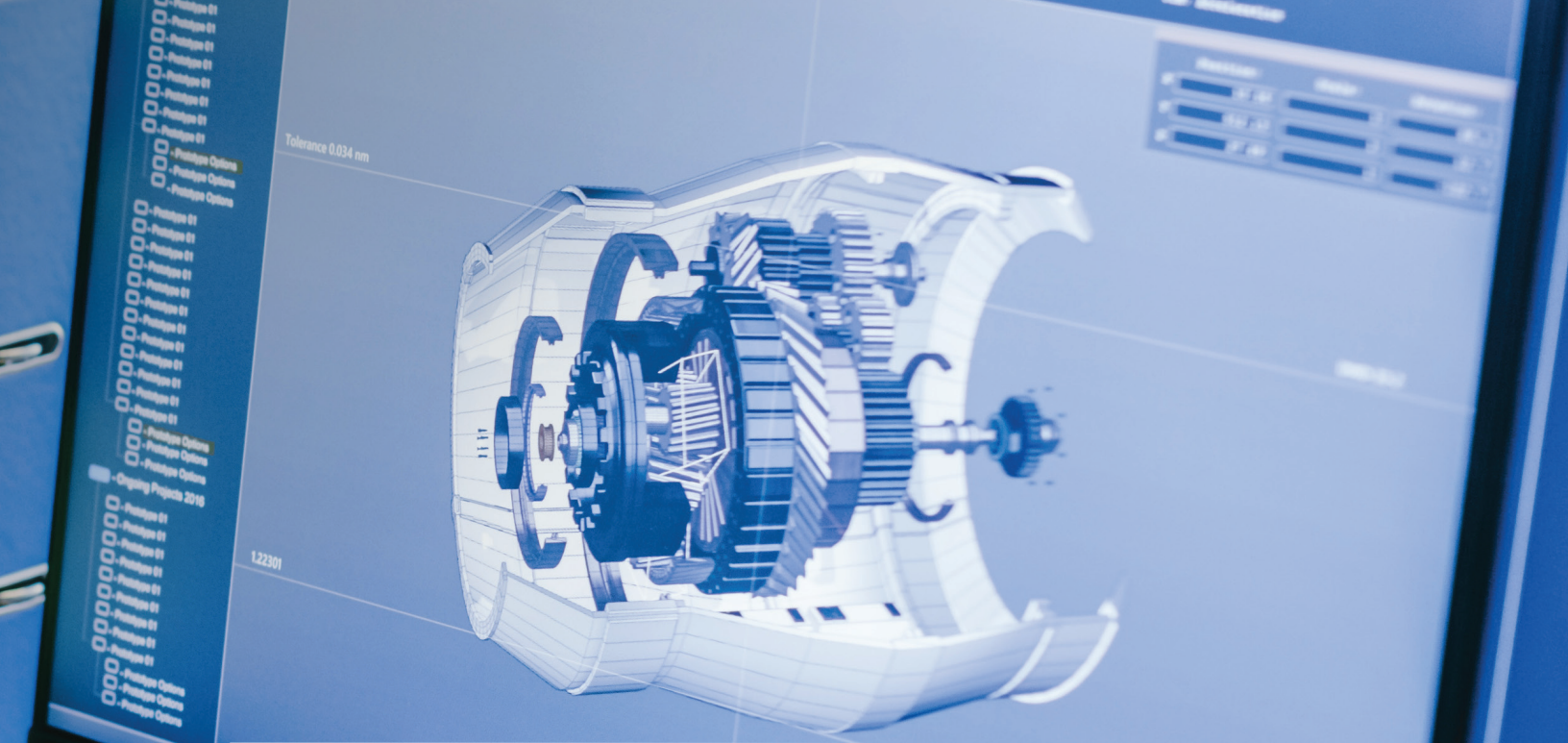

## SERVICES & TECHNOLOGIES

- Structural/Civil Engineering
- Reverse Engineering
- Electrical Engineering
- Mechanical Engineering
- Forensics/Accident Investigation
- Mechanical Engineering
- Forensics/Accident Investigation
- Lift Plan/Engineering
- Welding and Materials
- Finite Element Analysis (FEA)
- Fitness-for-Service (FFS) Evaluations
- Tmin (Minimum Allowable Thickness) Calculations for Service Water Piping Systems

## CERTIFICATIONS & GUIDELINES

- ISO/IEC 17025:2005
- ISO/IEC 17065:2012
- ITAR Registered
- FAR Part 145 Certification
- Federal Firearms License (FFL)
- Nadcap Accredited
- ASNT Certified Level II & III
- Full-Service Packages Available for Certification and Registration with the FCC, ISED Canada, MIC Japan, and CE European Union.
- We Can Issue Your Approvals for USA, CANADA, and EU Scope
- Accredited Certifiers
- Our Facilities Meet a Variety of MIL-SPEC, ANSI, ASTM, and ASME Specifications

# STRUCTURAL ENGINEERING

IIA is a leading supplier of structural engineering services for industrial, commercial, institutional and construction projects. Our goal is to provide our clients with cost-effective and high-quality engineering solutions.

Our core competencies are with steel and concrete design, with specialties in concrete foundations, concrete slab design, open web steel joist reinforcements, structural steel, and temporary shoring plans.

## INDUSTRIAL DESIGN & PLANT ENGINEERING SERVICES

- Mezzanines, Equipment Access Platforms, Catwalks, Canopies & More
- Loading Docks & Ramps
- Overhead Crane Structure Design / Upgrading / Engineered Lifts
- Other Shop Cranes / Below The Hook Design
- Building Modifications and Expansions
- Fall Protection Systems, Including
  - Horizontal & Vertical Lifeline Systems
  - Guard Railing
- Pre-Start Health And Safety Reviews (PSR's) for:
  - Lift Equipment
  - Industrial Racking
- Heavy Machine Foundations and Bases
- Rooftop Unit (RTU) Equipment Supports
- Open Web Steel Joist Reinforcement (OWSR) Design
- Smoke Stack Design
- General Structural Steel and Concrete Design

## COMMERCIAL BUILDING RESTORATION SERVICES

With expertise in steel and concrete structures, IIA provides building restoration engineering services to industrial, commercial, institutional, and hi-rise rehabilitation projects. Our project management team will ensure your project is completed on time and on budget, from start to finish.

You can rely on our professional engineers for the following:

- Rehabilitation of walls, parking garages, floor slabs, balconies, and foundations
- Structural reinforcement of existing structures
- Structural redesign/modification
- Open web steel joists reinforcement
- Temporary shoring, re-shoring, and scaffold design
- Building code compliance
- Concrete slabs, retaining walls, culvert design
- Repair procedures for concrete or steel structures
- Project management
- Project permitting & tendering



## CONSTRUCTION STRUCTURAL ENGINEERING SERVICES

Our engineers can handle small to midsize construction projects from beginning to end, including such critical stages as: concept drawings, final approved design, shop drawings and member connections for fabrication, third party fabrication sourcing (*if required*), and final visual inspection and nondestructive testing on fabrication and erection (*if required*).

Our services include:

- Engineering Support for Construction Projects
- Steel & Concrete Design for Building Add-Ons/ Expansions
- Demolition Plan & Review for Construction Projects
- Fall Protection Systems
- Critical Lift Planning
- Shop Drawing & Connections Design
- Pre-Condition & Pre-Construction surveys
- Roof Anchors & Davit Support Design
- Structural Analysis of Permanent or Temporary Structures
- Tower Crane Foundation Design
- Quality Verification Engineering (QVE)
- Structural Erection Plans

## OHSA REG 213/91

We can assist with construction engineering requirements relating to OHSA Reg 213/91:

- Access Platforms
- Formworks
- Shoring / Reshoring / Scaffold Design
- Elevating Work
- Hoisting & Rigging
- Mobile Cranes & Tower Cranes





# STRUCTURAL ENGINEERING

(CONT'D)

## OVERHEAD CRANE ENGINEERING & INSPECTION SERVICES

IIA provides expert design engineering and consultation services for the planning and layout of industrial overhead cranes of all types (single girder, double girder, top running and under running). We can supply you with data on the static and dynamic forces generated by an overhead crane operation, including the following:

- Maximum Wheel Load
- Side Thrust Load
- Collision Forces
- Overturning Moments (for free standing overhead crane systems)

These loads are essential and very important factors to consider when performing a proper analysis on all kinds of industrial buildings utilizing overhead cranes.

By proper analysis, the design engineer will be capable of assessing the following important structural members:

- Roof beams (in case the overhead crane is an under running, roof-mounted crane)
- Building columns and corbels (or stools)
- Building bracing system
- Building foundation

All other additional loads on the building resulting from the overhead crane supporting structure (i.e. runway beams)

## SHOP CRANE SERVICES

IIA also has the capability to custom design and assess the loads generated by existing crane types, including jib cranes, gantry cranes, workstation cranes and monorail systems.

## PRE-START HEALTH AND SAFETY REVIEWS (PSR'S/PHSR'S)

Our engineers can perform PSRs on newly installed or newly modified cranes.



## FALL PROTECTION EQUIPMENT TESTING

IIA can help your company set up proper fall protection measures to prevent employees from falling off elevated workstations, overhead platforms, and any work at heights. Our engineers can also inspect and recertify your fall arrest system as safe for use after the system has been used to arrest a fall.

Our complete fall arrest engineering system & package includes the following:

- [Plan & Elevation Layout](#)
- [Anchor Design & Locations](#)
- [Proper Installation Instructions](#)
- [Lifeline Specifications](#)
- [Maximum Persons & Weights](#)

Our engineers and inspectors can also assist with:

- [Vertical Life Lines](#)
- [Lanyard Arrest Anchor Points](#)
- [Developing Rescue Procedures](#)
- [Inspection of Fall Protection Systems, Harnesses, Lanyards, etc.](#)

## STAGE & ENTERTAINMENT ENGINEERING SERVICES

We engineer solutions for various production companies and art festivals that ensure safety standards are upheld without compromising the aesthetics or functionality of the artist's vision.

Our engineers can help with the design of structures and mechanical systems for performance venues, entertainment productions, unique art exhibits, and more.

IIA can help engineer your project from the concept stage, stage production inspections to final construction. We can assist with any type of structures involving Christie lites, staging, high-strength cables, complex suspension systems, foundations/supports for heavy exhibits, and more.

Whatever the project, we will select the materials, develop the specifications, and establish the construction method needed to make it work.

## LIGHT POLE & SIGN STRUCTURE DESIGN SERVICES

IIA provides a complete turnkey solution for the design and fabrication of the following structures:

- [Commercial & Highway Light Poles](#)
- [Mounted, Suspended, and Free Standing Signs](#)

Our complete engineering package includes an engineered design and shop drawings. Design load calculations consider factors such as wind (including vortex shedding action), seismic, ice, vibration, and fatigue. All designs are done in accordance with relevant codes and standards. Our material expertise includes steel, aluminum, and wood.

## REINFORCED CONCRETE STRUCTURE DESIGN SERVICES

- [Retaining Walls](#)
- [Concrete Underground Storage Tanks](#)
- [Piles – H-Piles, Concrete \(bored or driven\)](#)
- [Caissons](#)
- [Rooftop Engineering \(e.g., mechanical units, changes to occupancy\)](#)
- [Water Treatment Plants](#)
- [Building Repairs](#)
- [Building Framework Design/Repair](#)
- [Parking Garage Design/Repair](#)

## CERTIFICATIONS & GUIDELINES

- [AASHTO](#)
- [ASME](#)
- [AWS](#)
- [CSA/CWB](#)
- [CSA S6](#)
- [CSA S16](#)
- [CSA W47.1 Division 2](#)
- [ISO 9001: 2015 Registered QMS](#)
- [ISO/IEC 17025:2005](#)
- [ISO/IEC 17065:2012](#)
- [OSHA Reg 213/91](#)
- [Registered by the Canadian Welding Bureau under CSA W178.1](#)



# MECHANICAL ENGINEERING

**IIA offers a wide variety of mechanical engineering services around the following areas:** lift equipment, lift planning, machine design and drafting, design validation, finite element analysis (FEA), fitness-for-service (FFS) evaluations, Service Water T<sub>min</sub> calculations, fall protection services and automated inspection systems.

## **PRE-START HEALTH & SAFETY REVIEWS**

- Industrial lift equipment
- Storage racking

## **MACHINE DESIGN & DRAFTING**

- Computer Aided Design (CAD) and engineering
- Machine design of shafts, gearboxes, bearing springs and more
- Heavy duty construction and mining engineering design
- Equipment design, modification and CAD conversion
- 2D / 3D drafting and part detailing
- CAD model reverse engineering from photo or sketch

## **FALL PROTECTION SYSTEMS**

- Horizontal Static Lines
- Lanyard Arrest Anchor Points
- Confined Space Rescue Systems
- Rescue Procedure Development
- Fall Arrest

## **FINITE ELEMENT ANALYSIS**

- Linear Stress Analysis
- Static Stress Analysis
- Dynamic Analysis
- Fatigue Analysis
- Buckling Analysis
- Vibration, Impact or Drop Test Stress Analysis

## **LIFT EQUIPMENT**

- Design or Modification to Existing Equipment
- Load Rate Existing Equipment
- De-Rate Equipment
- Custom Lift Design
- Manbaskets & Spreader Beam

## **AUTOMATED INSPECTION SYSTEMS**

- Custom Inspection System Design and Build
- Modifications to Existing Inspection Equipment
- Design and Build Probe Holders for Unique Applications
- Machining Services



## DESIGN VALIDATION

### PRODUCT DESIGN VALIDATION & REVIEW

Many of our industrial clients have their own in-house product designers and CAD detailers, but lack in-house engineering capability. We can provide an engineering review of your product design to ensure it meets appropriate safety standards and is fit for use.

### PRODUCT DESIGN REVIEW & VALIDATION SERVICES

Our experts can assist you with the following tasks:

- Research & recommend appropriate design standards
- Perform required design calculations
- Design validation, verification, optimization, and certification
- Compliance review
- Load testing & stability testing
- Measure components and develop production-ready drawings
- Develop full 3D CAD sub-assembly and complete assembly drawings
- Optimize designs to save weight, cost, or increase operating capabilities

- Consider alternate materials for design improvements
- Prescribe, witness & document performance tests
- Feasibility Studies
- Sub-Assembly or Complete Assembly Drawings
- Roll Over Protection Systems

### PRODUCT TYPES

Products we review include:

- Mining equipment & vehicles
- Lift devices
- Aerial equipment
- Jackstands & racking
- Access platforms (mezzanines, catwalks, etc.)
- General machinery
- Roll-over protection

### HAVE EQUIPMENT THAT'S NEVER BEEN PROPERLY RATED?

Our engineering experts can analyze existing lift equipment that's never been rated and provide an accurate load/capability rating and a letter of certification.

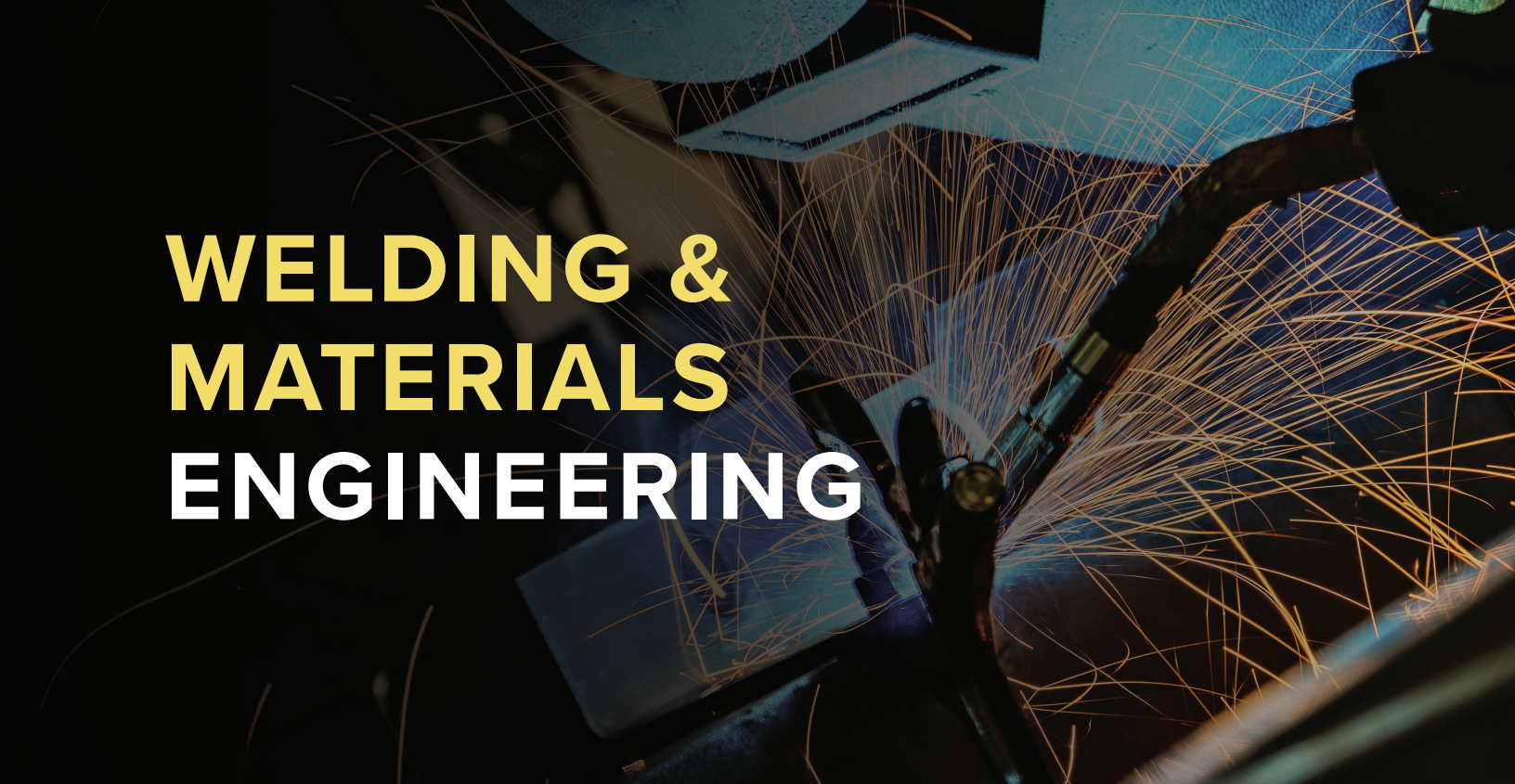

# WELDING & MATERIALS ENGINEERING

**IIA is a trusted provider of welding engineering services to a variety of industries**, including lift, mining, petrochemical/chemical, pipeline, and metal fabrication (steel and aluminum).

Our services include the following:

- Retained Engineer Services for CWB Companies
- Weld Procedure & Data Sheet Development
- Welder Qualification
- Weld Failure Analysis
- Welded Product Design

## CODE CERTIFICATION

Prepare specifications to any of the following codes and standards:

- ASME
- CSA / CWB
- AWS
- Validation
- Coordinate testing to validate welding procedures
- Document validation testing
- Provide Welding Procedure Specifications (WPSs) and Data Sheets (WPDSs) required for certification

## WELD PROCEDURES

We develop procedures for the following product categories:

- Industrial and heavy equipment
- Pressure vessels and piping
- Pipelines
- Structures

## OTHER SERVICES

- Consulting services
- Engineered Weld Repairs
- Metallurgical assessment and failure analysis for mechanical process equipment or welded components
- Codes and standards interpretation



# INCIDENT INVESTIGATIONS & EQUIPMENT VALIDATION

**When a lift does not go according to plan, or an equipment failure causes an accident, IIA can help you quickly get to the root cause.** Our team is prepared to conduct (or oversee) a thorough, unbiased investigation and provide engineering solutions to ensure equipment will not endanger workers. Along the way, we will help you navigate regulatory requirements for accident reporting and resolution.

As a trusted leader in equipment integrity, we are frequently called upon to provide expert witness testimony in legal proceedings. Clients also partner with us for subrogation services that can reduce insurance costs. We bring an eye for detail to every investigation and experience that spans decades and industries.

## **OUR TEAM OF EXPERTS CAN HELP YOU:**

- Determine the reasons behind a misadventure or equipment failure
- Meet Ministry of Labour or other regulatory requirements for accident reporting
- Reduce insurance costs through subrogation of accident responsibility
- Expert witness services in court proceedings

## **CERTIFICATIONS & GUIDELINES**

- Certified Professional Engineers
- CWB 178.1 Certified Organization
- CWB 178.1 Level II and III Personnel
- CWB Certified CSA W178.10
- CGSB Certified Level II Personnel
- CSA Z150
- CSA Z151
- CSA B354.7
- CSA B335
- Federal & State Occupational Safety and Health Administration
- ASME B30
- ANSI B56.1
- ASNT Certified Level II and III
- ISO 9001: 2015 Registered QMS
- ISO 20474-5

# LIFT PLANNING & ENGINEERING SERVICES

## ENGINEERED CRITICAL LIFTS & RIGGING STUDIES

Engineered critical lifts help to ensure the safe delivery of any heavy load, and IIA has years of experience doing them.

Our services include the following:

- Provide plan, elevation, rigging studies, and matting drawings as required
- Select appropriate cranes based on capacities, accessibility, and availability
- Size up rigging (rigging studies)
- Lift equipment design and custom rigging design
- Specify the crane location(s) and the initial position of the load
- Ensure that outrigger/crawler loads do not exceed soil capacity
- Inspect and certify crane and rigging equipment
- Check boom, load, rigging, and swing clearances during the erection and lifting phases
- Detail the lift sequence, including tandem lifts
- Provide safety precautions related to wind, communications or other site-specific hazards
- Perform pre-start visit to ensure crane and rigging set-up follows lift plan

## CERTIFICATIONS & GUIDELINES

- CSA B354
- CSA Z150
- CSA Z248
- CSA C225
- NFPA 1914

## CUSTOM LIFT EQUIPMENT DESIGN

Along with our catalogue of pre-engineered lifting products, we design and supply a variety of custom lift equipment to meet your unique needs, including:

- Custom Lifting Beams
- Manbasket and Manbasket Adapters
- Gantry Cranes and Monorails
- Pallet Lifters
- Coil Hooks
- Coil Lifting Frames
- Tongs
- Jib Cranes
- Forklift Booms
- Fork Extensions
- Wheel/Pallet Lifters
- Unique Equipment

## CONCERNED ABOUT YOUR EXISTING EQUIPMENT?

Don't scrap it! If you already have existing lift equipment that has not been properly load rated, our team of engineers and inspectors can certify it to ensure it meets local codes and regulations.

## ENGINEERED WELD REPAIR PROCEDURES

Has your crane sustained structural damage and you're not sure how to fix it properly? We can engineer a procedure that can help safely prolong the life of your equipment.

## SPREADER BEAMS

IIA has a diverse product line of adjustable, pre-engineered, and fabricated on-demand spreader beams and lifting beams. We also inspect and certify spreader beams and lifting beams in accordance with local regulations.

# REVERSE ENGINEERING



**IIA is one of the original pioneers in using 3D scanning for reverse engineering, geometry recreation and 3D modeling.** Our process is highly refined and optimized around many industry-specific challenges. IIA provides reverse engineering services to an array of industries, including medical device, heavy equipment, firearms, as well as tooling and plastic companies.

## BEFORE WE BEGIN

Before you start your next modeling or reverse engineering project, here are some things to consider:

- Have an idea of how this file will be used. What are the “next steps” for this model once returned to you? (This is very helpful to us when quoting.)
- Provide photos of all different sides of the part. We need a good understanding of the size, shapes, and features involved.
- Your requirements for detail/accuracy to the physical part.

## MODELING PLATFORMS (SOFTWARE)

IIA can build files for use in any modern software, as well as many legacy platforms. Our primary platforms are SolidWorks and Creo/Pro-E, each fully up to date with the latest versions. (We often retain legacy licenses for those customers who need it). If we do not have your CAD software of choice, we can output neutral file formats such as .igs, .stp, .x\_t, and many more.

## VERIFICATION & PROJECT HANDOFF

Accuracy is paramount to the quality and the success of any reverse engineering project. IIA utilizes our own Deviation Analysis process to ensure that each feature and each characteristic is accurate to the scanned part. It's used throughout the reverse engineering process as the model tree grows with every additional feature and every iteration.

Every project ends with a conference call or screen share to ensure that the results are understood and fit your requirements. Deviation Analysis is used here as a final proof-of-work at the end of every reverse engineering project to demonstrate a precise point-by-point comparison that what we have created matches your physical part as scanned. This level of precision in verification is virtually impossible with manual methods. A Deviation Analysis makes full verification cost-effective and is critical to assure the accuracy of the resulting model.

## CERTIFICATIONS & GUIDELINES

- Certified Professional Engineers
- CWB 178.1 Certified Organization
- CWB 178.1 Level II and III Personnel
- CGSB Certified Level II Personnel
- CSA Z150
- CSA Z151
- CSA B354.7
- CSA B335
- CWB Certified CSA W178.10
- Federal & State Occupational Safety and Health Administration
- Federal Firearms License (FFL)
- ASME B30
- ANSI B56.1
- ASNT Certified Level II and III
- ISO 9001: 2015 Registered QMS
- ISO 20474-5

# MECHANICAL INTEGRITY SERVICES



A mechanical integrity program employing methods of nondestructive testing to detect structural flaws in process plant equipment, can go a long way towards keeping your working environment safe. We specialize in inspecting the following types of equipment:

## ABOVE-GROUND STORAGE TANKS

- API 653 inspection
- Visual inspection
- Magnetic flux leakage floor testing
- Ultrasonic testing (A & B scans)
- Vacuum box testing of lap welds
- Corrosion surveys
- Foundation & settlement surveys
- Wall crawler UT corrosion mapping

## PRESSURE VESSELS

- API 510 inspection for planned outages
- Visual & remote visual inspection (RVI)
- Wall thickness readings
- Magnetic particle/liquid penetrant inspection

## PIPING/PIPE RACK STRUCTURES

- API 570 inspection for planned outages
- External visual
- Internal visual/borescope inspection
- Ultrasonic thickness testing
- NDT on nozzles/appurtenances

## HEAT EXCHANGER & BOILER INSPECTION

- Internal rotary inspection system (IRIS)
- Remote field testing (RFT)
- Eddy current (ECT)

## WATER TREATMENT/PROCESSING PLANT EQUIPMENT

- Internal rotary inspection system (IRIS)
- Remote field testing (RFT)
- Eddy current (ECT)



# ELECTRICAL ENGINEERING



**Our team includes electrical engineers dedicated to designing, building and enhancing automated inspection tools to meet our customers' unique needs.**

IIA offers an array of Electrical Engineering services related to automated inspection systems. To complement our engineering services, IIA also has a machine shop where we can custom-build parts and assemblies, both electrical and mechanical.

## **AUTOMATED INSPECTION SYSTEMS**

- Control System Design for Remote-Operated Vehicles (ROVs)
- Programming Capabilities
- Design, Build & Validate Non-Destructive Testing (NDT) Equipment
- Electrical System Troubleshooting
- Circuit Board Design

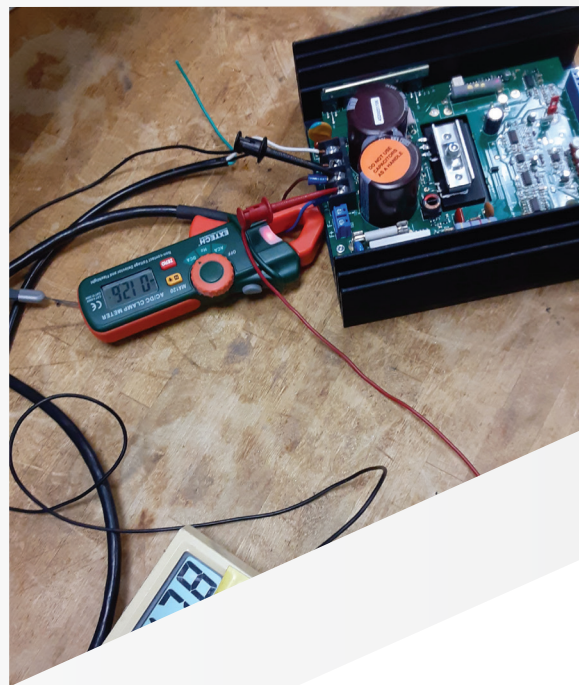



# THE IIA PATENTED TECHNOLOGIES ADVANTAGE

## PROPRIETARY TECHNOLOGY

IIA has innovative technology that provides reliable results and enables the safe operation of your plant. The AIRIS® robotic scanner easily moves around internal components, and our Steam Generator Nozzle Examination Tool (SG-NExT) provides internal surface inspections. IIA's ARMUT® uses QR code film on complex geometry to examine critical welds, and the Automated Nozzle Tool System (ANT2) performs nozzle exams without obstructing the center of the reactor.

## TECHNOLOGIES

We use a combination of Conventional, Specialty, and Proprietary technologies, including PASS, AIRIS, ANT2, and ARMUT®. IIA's proprietary ARMUT® technology uses QR code film on complex geometry and is used to examine critical welds and gather extremely high-resolution images. Our Automated Nozzle Tool System (ANT2) is used to perform nozzle exams without obstructing the center of the reactor and exams can be completed with or without the Core Barrel in place.

## THE ARMUT® ADVANTAGE

### Simple & Advanced Manual Encoded Ultrasonic Testing

IIA's ARMUT® technology is the most cutting-edge PAUT examination available today. It's an alternative to conventional manual and encoded track phased array examinations. Our patented ARMUT® system offers a reliable, time-saving alternative for corrosion mapping of piping elbows. Armed with ARMUT, a single technician can capture high-resolution images along the entire pipe elbow. You'll receive an accurate map of corrosion that will pave the way for sound maintenance and repair decisions.

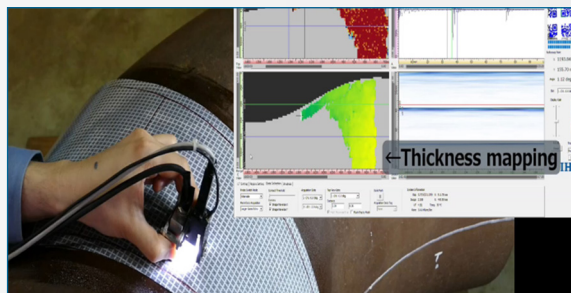

## AIRIS™ ROBOTIC SCANNER

### Advanced Inspection of Reactor Vessel & Internals

We understand that time is money. IIA's advanced AIRIS™ inspection method delivers more reliable data while saving plant owners time, trouble and cost.

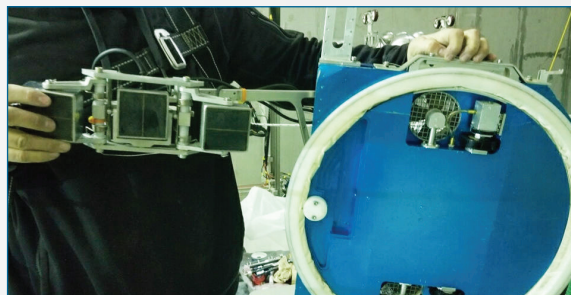

## PASS®

### Accurate Valve Data — Without Disassembly

Valve disassembly is a costly and time-consuming prospect that requires the system to be placed in an at-risk condition. IIA's Phased Array Sectorial Scanning (PASS®) allows for highly accurate valve testing — without disassembly.

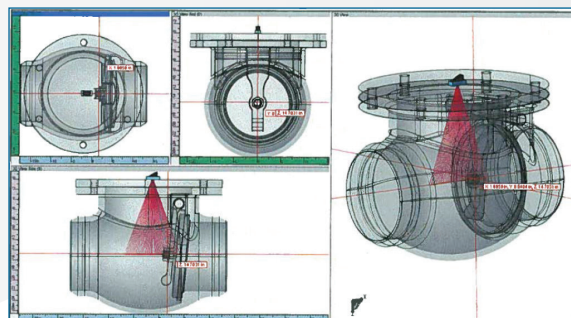

# OUR NATIONAL FOOTPRINT

IIA has an extensive national footprint and an ever-expanding global presence in the industrial sector.

We are a leader in this market within the United States and Canada.



## HUNDREDS OF EXPERTS SERVING YOU

*IIA's hundreds of employees are all knowledgeable, curious, and professional, and each has a unique skill set that ensures best-in-class service for you.*



## LOCATIONS ACROSS THE GLOBE

*IIA operates many field offices and laboratories across the United States and also operates offices in Canada and China.*



***Making the World Safer***



**Corporate Headquarters**  
3625 Brookside Parkway,  
Suite 475  
Alpharetta, GA 30022

11/2024 IIA Services

**844-982-0747**  
**industrial-ia.com**